

PITMEC

THE PCON-E 305 CONCENTRIC UNDERREAMING SYSTEM

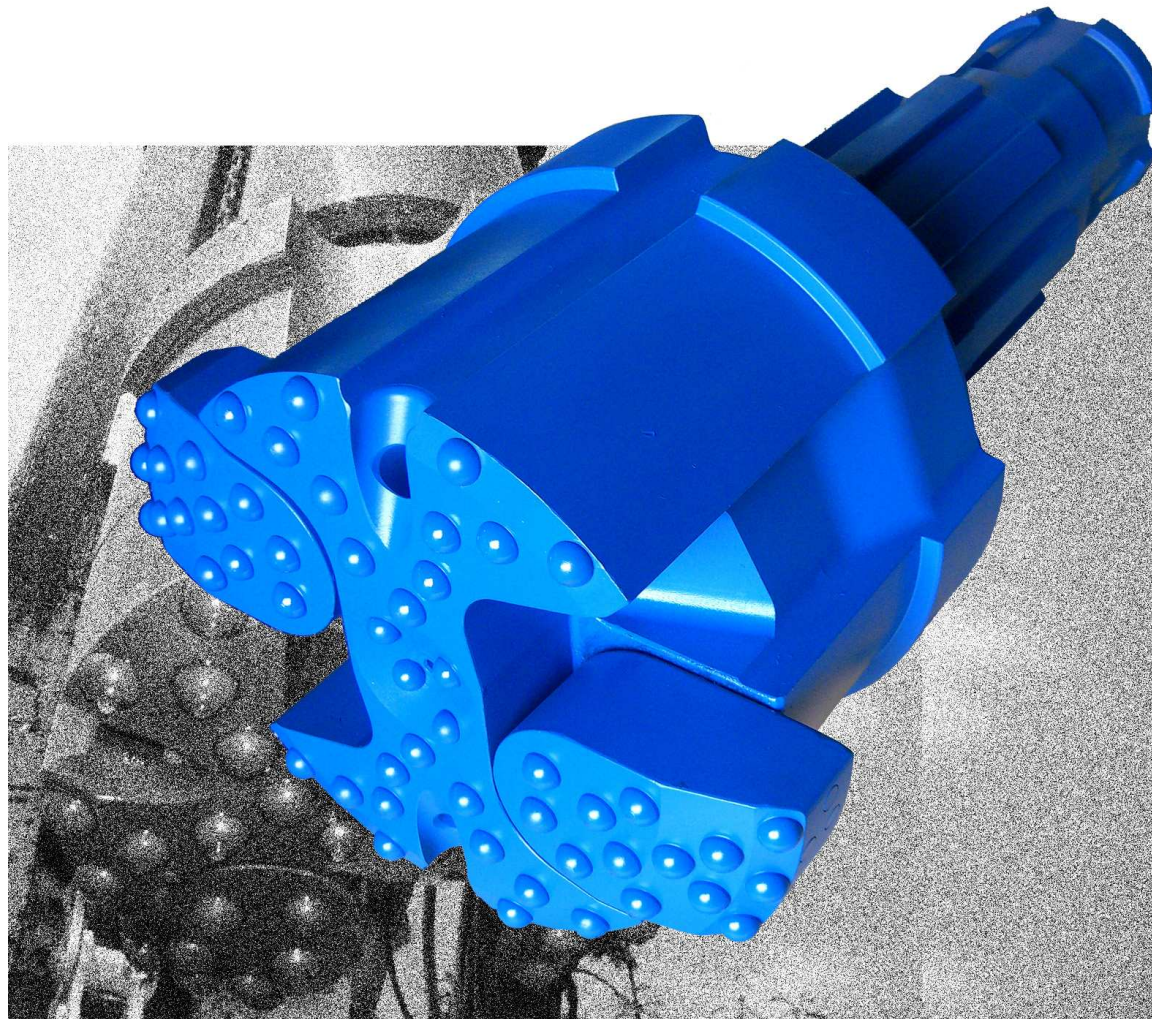

CASING SIZE 355MM OD X 330MM ID DRILLING DIA. 380MM

PNEUMEC PCON-E 305 CONCENTRIC UNDERREAMING SYSTEM

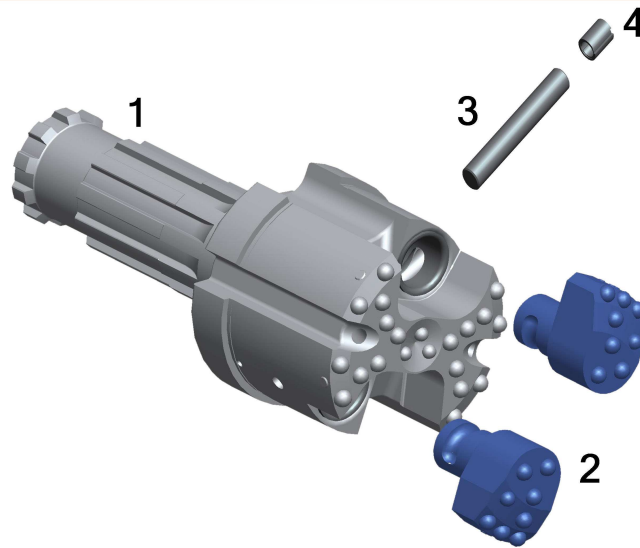

PCON-E 305 PARTS LIST

1.	DRIVER BIT SD12 SHANK	UGD305S12PCE
2.	REAMER(2)	UBS305PCE
3.	LOCKING PIN	USP30550PCE
4.	SPLIT PIN	USP30551PCE
5.	COMPLETE SYSTEM	UCS305S12PCE

PCON-E 305 SPECIFICATIONS

UPPER BODY DIAMETER	327MM	CLOSED DIAMETER	305MM
REAMING DIAMETER	380MM	CASING SIZE	355MM OD X 330MM ID
SYSTEM LENGTH	728MM	SYSTEM WEIGHT	260KG

PCON-E 305 CASING SHOES

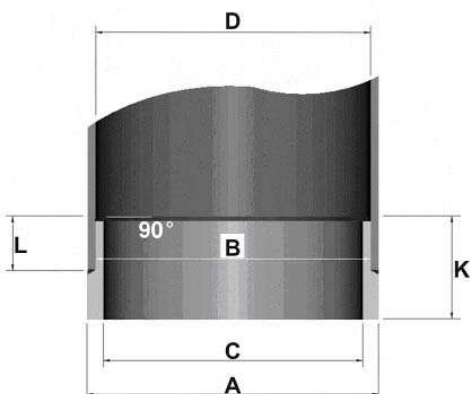

DIA. A	355MM
DIA. B	327MM
DIA. C	307MM
DIA. D	330MM
L	55MM
K	115MM

PNEUMEC

PNEUMEC COMPANY LIMITED

1st Floor, Tin On Sing Comm. Bldg., 41-43 Graham St. Central, H.K.

Tel : (852) 2305 9922

Website : www.pneumec.com

Fax : (852) 2305 9982

email : info@pneumec.com